



## COMPACT SAFETY EVAPORATOR TYPE CSE

### For highest dosing performance.

When higher dosing outputs are required, e.g. over 40 kg Cl<sub>2</sub>/h, our compact evaporators are available to provide a continuous gas supply.

Capacities up to:

- » 100 kg Cl<sub>2</sub>/h
- » 200 kg Cl<sub>2</sub>/h

The evaporator is supplied with all operating and safety equipment including control and monitoring system.

### Compact Safety Evaporator for evaporation of liquid chlorine.

The main components of the CSE type evaporator are:

- » Closed and heated water bath, corrosion-resistant, with temperature measurement, control and alarm function for temperature HIGH/LOW as well as pressure compensation appliance
- » Electric heater with thermostat
- » Circulation system for water bath
- » Overpressure safety system
- » Overpressure vessel with pressure indication and alarm contact
- » Pressure indication for the operating pressure with alarm contact min./max.
- » Evaporator pressure tank with cleaning connection

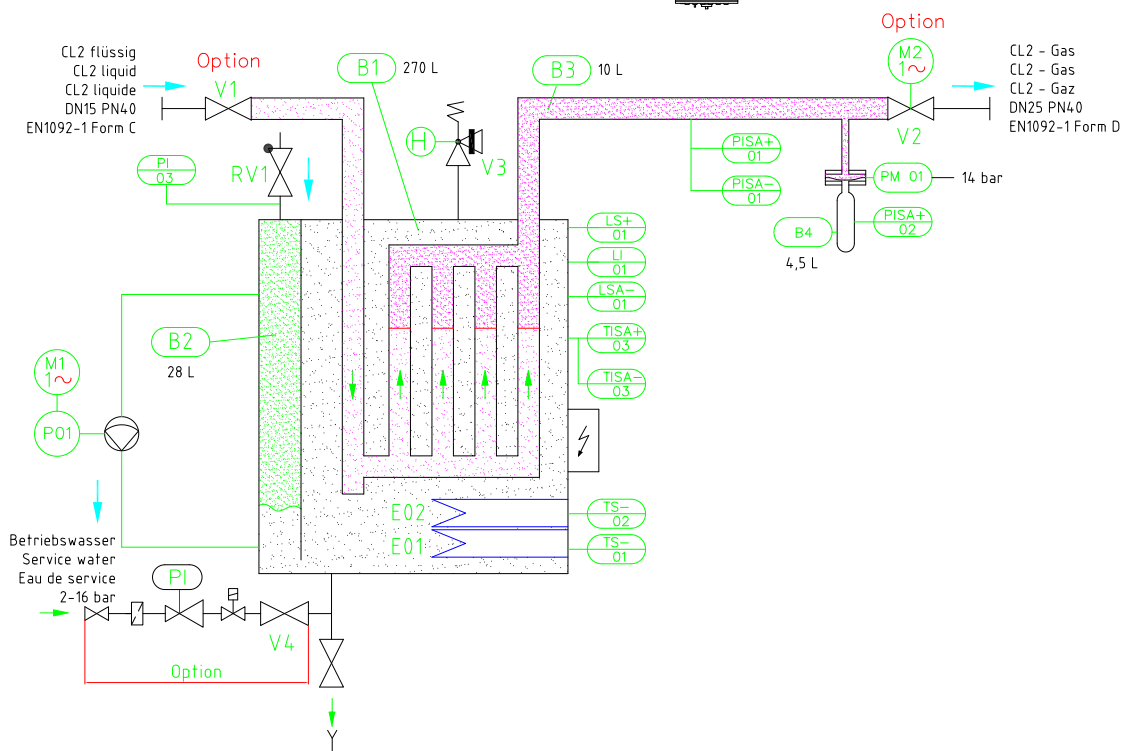
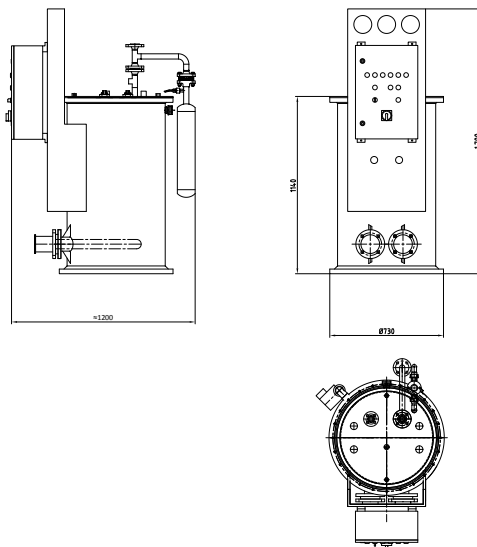

## Alltech Dosieranlagen GmbH

Rudolf-Diesel-Str. 2  
76356 Weingarten  
Germany

P.O. Box 1120  
76352 Weingarten  
Germany

Phone: +49-7244-70 26-0  
Fax: +49-7244-70 26-50

info@alltech-dosieranlagen.de  
www.alltech-dosieranlagen.de

**Alltech**  
Dosieranlagen  
mit Know-how