

MOTHER TANK

IBC handling safe, simple and convenient

Alltech Mother Tank is a storage system for the **safe handling of standard IBCs** 1200 x 1000 mm, consisting of:

- Mother Tank 2 m³ with top surface for stacking on IBC, inspection opening, filling connection, overflow with siphon, vent, mechanical level indication
- Integral safety bund 2 m³. The **integral safety bund protects the environment** in case of spillage.
- Other accessories (e.g. discharge, ultrasonic level measurement, agitator) on request.
- Can also be supplied on request with design certificate of the DIBt, according to WHG

Simplicity: IBCs are placed directly on top of the Mother Tank by fork lift truck or other lifting gear and completely emptied into the tank.

Convenience: The bigger capacity of the Mother Tank allows a **continuous feeding of the dosing system** within a wide time slot. A new IBC can already be drained, when there are still 10-50 % of chemical available in the tank.

Safety: The integral safety bund protects the environment in case of spillage.

Dimensional drawing Mother Tank

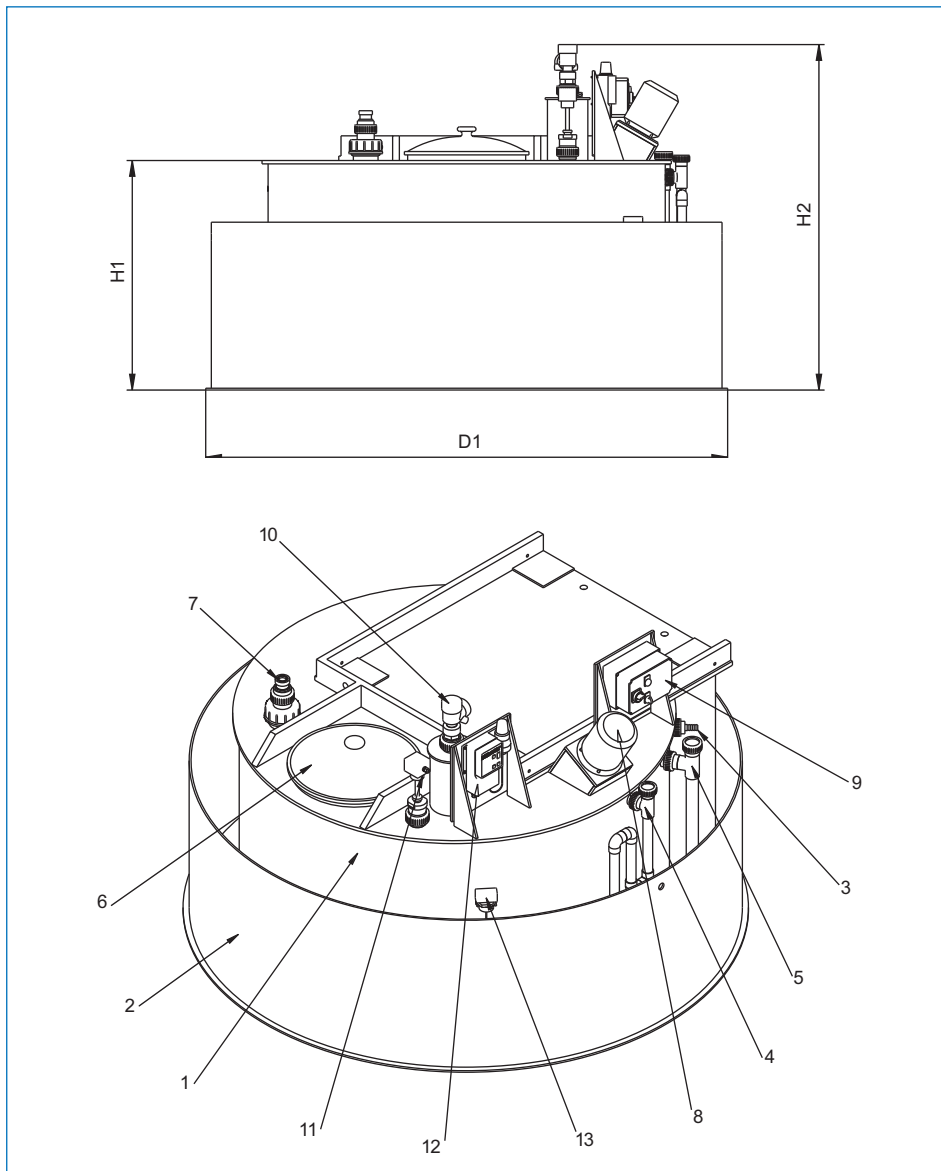

- 1) Tank
- 2) Collecting bund
- 3) Filling DN 32 – 25/37
- 4) Overflow DN 32
- 5) Tank level indicator DN 40
- 6) Inspection hole DN 500
- 7) Discharge (option)
- 8) Agitator (option)
- 9) Control panel for agitator (option)
- 10) Ultrasonic level sensor (option)
- 11) Overflow sensor (option)
- 12) Alarm system (option)
- 13) Leakage detector (option)

V [m ³]	D1 [mm]	H1 [mm]	H2 [mm]	H3 [mm]
2	2330	1025	1425	1560

Alltech Dosieranlagen

Rudolf-Diesel-Straße 2
76356 Weingarten
Germany

P.O. Box 1120
76352 Weingarten
Germany

Phone: +49 | 72 44 | 70 26-0
Fax: +49 | 72 44 | 70 26-50

E-mail: info@alltech-dosieranlagen.de
Internet: www.alltech-dosieranlagen.de

Alltech
Dosieranlagen
mit Know-how